

8 7 6 5 4 3 2 1

DO NOT SCALE DRAWING
FOR REFERENCE ONLY

D

C

B

A

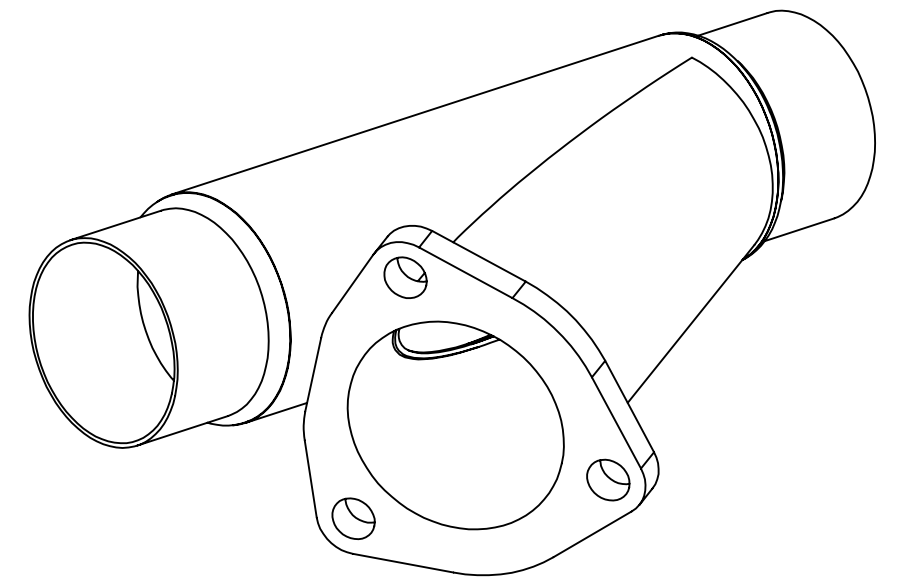
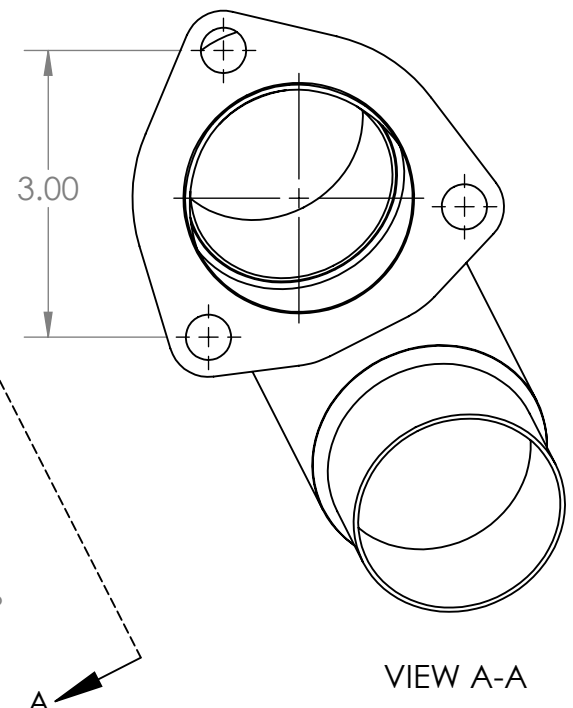
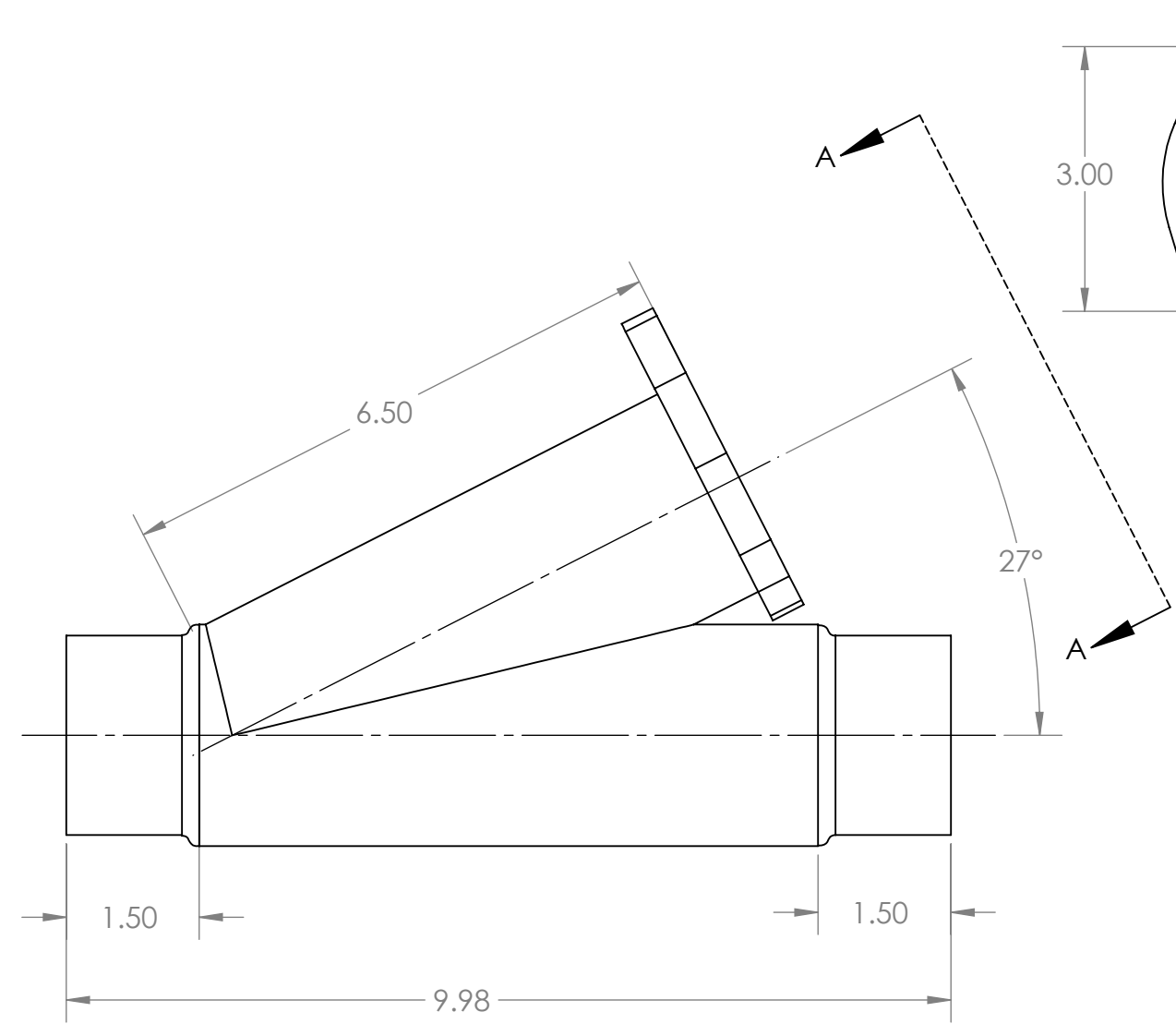

D

C

B

A

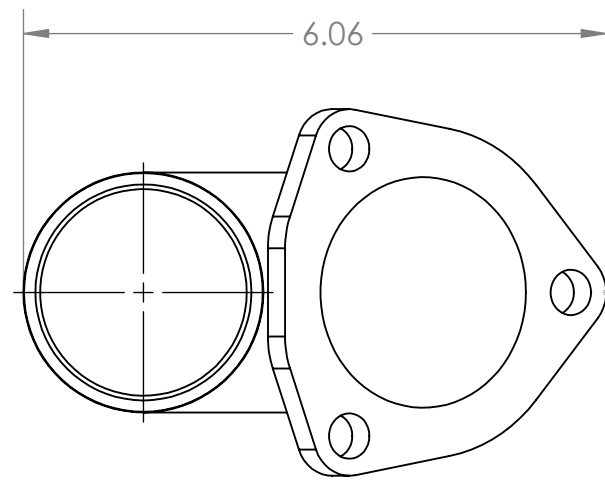
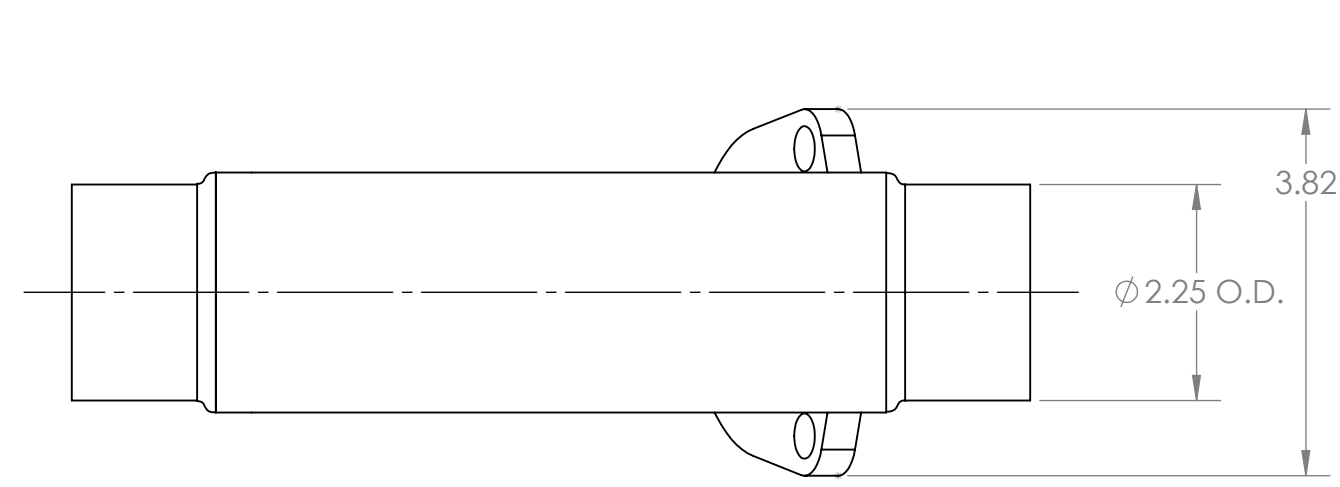

8 7 6 5 4 3 2 1



UNLESS OTHERWISE SPECIFIED:			
INTERPRET WELDING SYMBOLS PER AWS A2.4:2007		INTERPRET DIMENSIONS & TOLERANCES PER ASME Y14.5M-1994	
INTERPRET SURFACE TEXTURE SYMBOLS PER ASME Y14.36-1996		FILLETS R.002/R.020	
3RD ANGLE	UNITS: INCHES	BREAK EDGES .002/.020 RADIUS OR CHAMFER	
		GENERAL FINISH 128 Rq MAX	
MATERIAL		REMOVE ALL BURRS	
THIS DRAWING AND THE CONTENTS HERIN ARE CONFIDENTIAL AND THE SOLE PROPERTY OF QUICK TIME PERFORMACNE REPRODUCTION OF THIS DRAWING OR CONSTRUCTION OF ANY PARTS WITHIN THIS DRAWING ARE FORBIDDEN WITHOUT PRIOR WRITTEN CONSENT			
FINISH	DRAWN BY MP	DATE 4/20/2020	CHECKED BY DATE
COMMENTS	TITLE: 2.25" STAINLESS CUTOUT		
WEIGHT:	SIZE	DWG. NO.	REV
SHEET 1 OF 1	SCALE: 1:2	B	10225_PDS