

8 7 6 5 4 3 2 1

DO NOT SCALE DRAWING
FOR REFERENCE ONLY

D
C
B
A

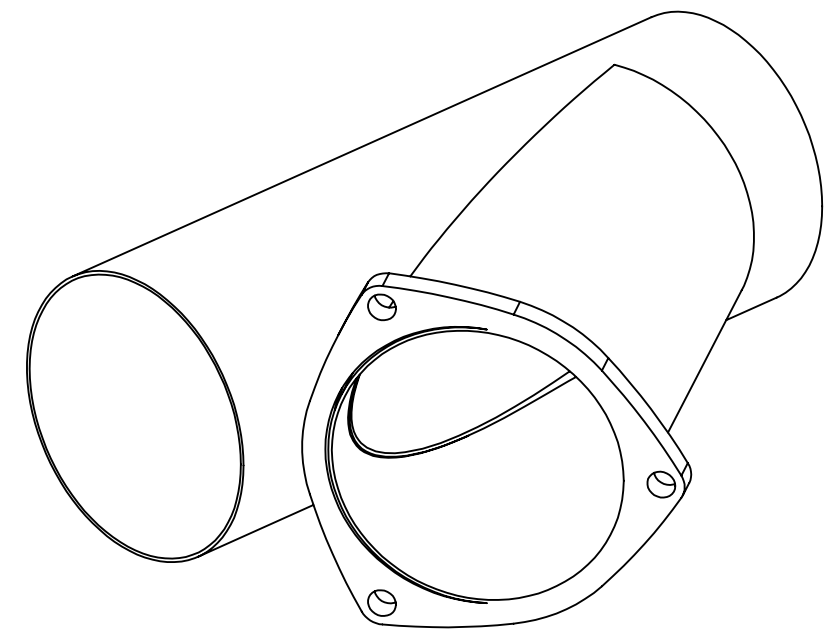
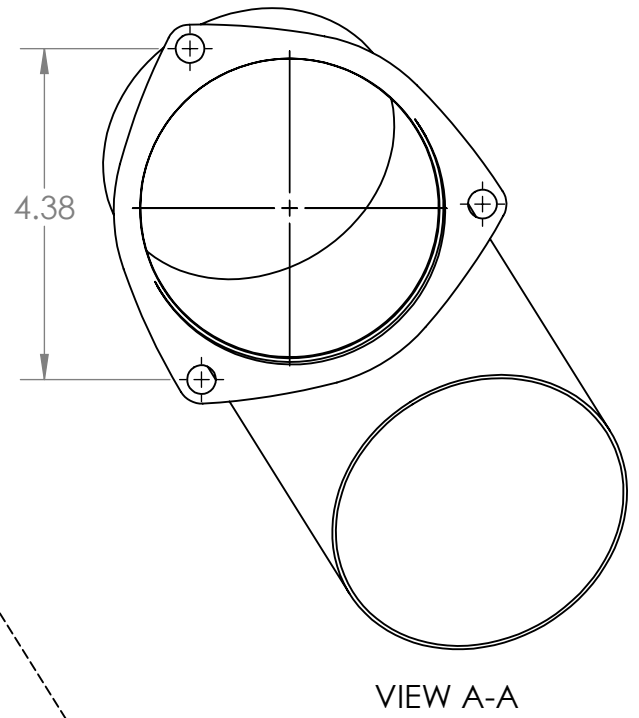
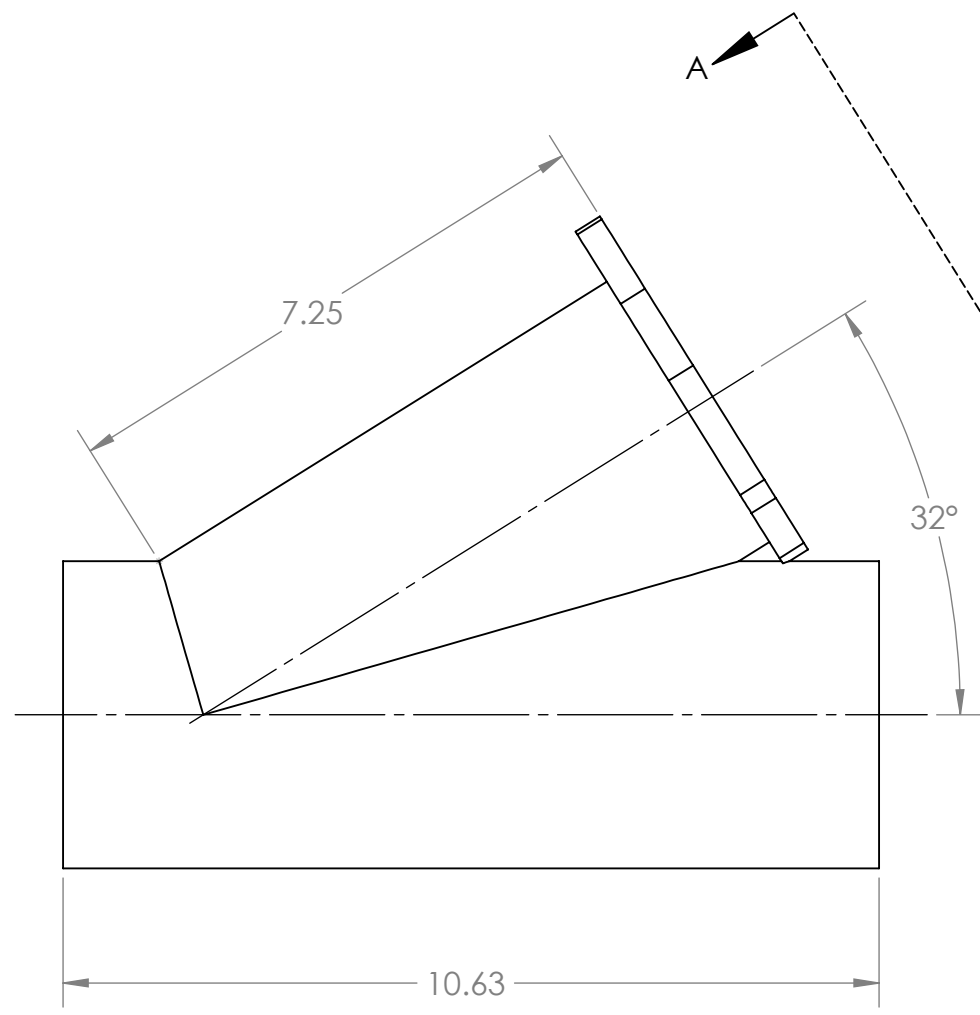

D
C
B
A

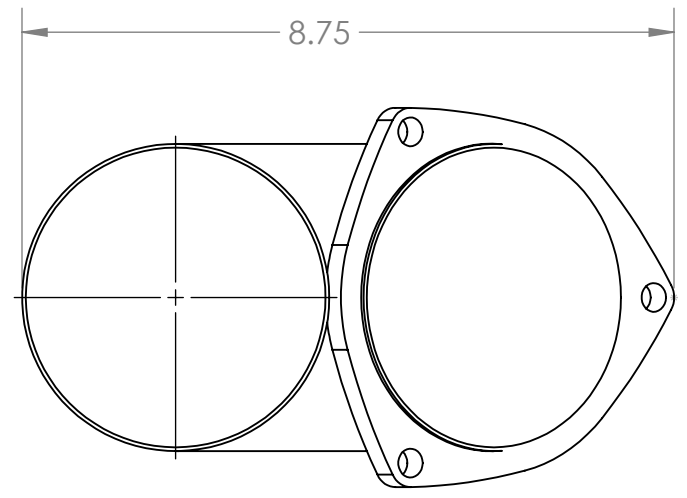
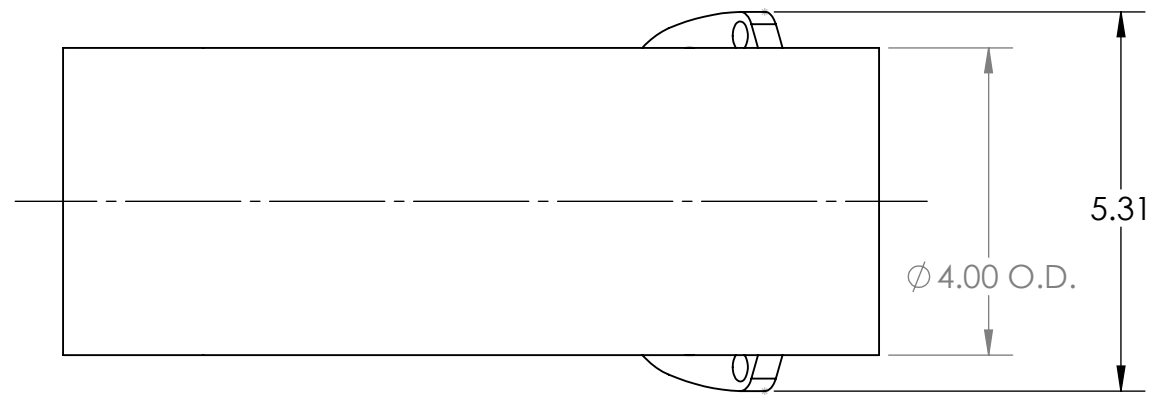

UNLESS OTHERWISE SPECIFIED:			
INTERPRET WELDING SYMBOLS PER AWS A2.4:2007		INTERPRET DIMENSIONS & TOLERANCES PER ASME Y14.5M-1994	
INTERPRET SURFACE TEXTURE SYMBOLS PER ASME Y14.36-1996		FILLETS R.002/R.020 BREAK EDGES .002/.020 RADIUS OR CHAMFER GENERAL FINISH 128 Rq MAX REMOVE ALL BURRS	
3RD ANGLE 	UNITS: INCHES	ONE PLACE ± .030 TWO PLACES ± .020 THREE PLACES ± .010 ANGULAR ± 1	
MATERIAL	THIS DRAWING AND THE CONTENTS HERIN ARE CONFIDENTIAL AND THE SOLE PROPERTY OF QUICK TIME PERFORMACNE REPRODUCTION OF THIS DRAWING OR CONSTRUCTION OF ANY PARTS WITHIN THIS DRAWING ARE FORBIDDEN WITHOUT PRIOR WRITTEN CONSENT		
FINISH	DRAWN BY MP	DATE 4/20/2020	CHECKED BY DATE
COMMENTS	TITLE: 4.0" STAINLESS CUTOUT		
WEIGHT:	SIZE B	DWG. NO. 10400_PDS	REV
SHEET 1 OF 1	SCALE: 1:2.5		

8 7 6 5 4 3 2 1