

FOR REFERENCE ONLY

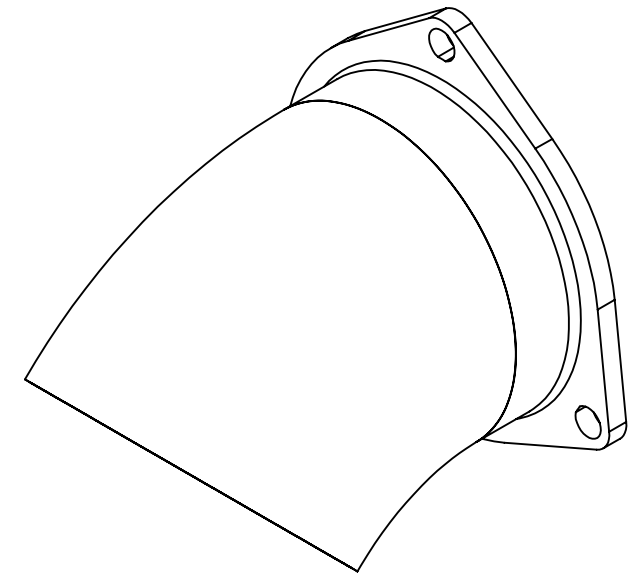
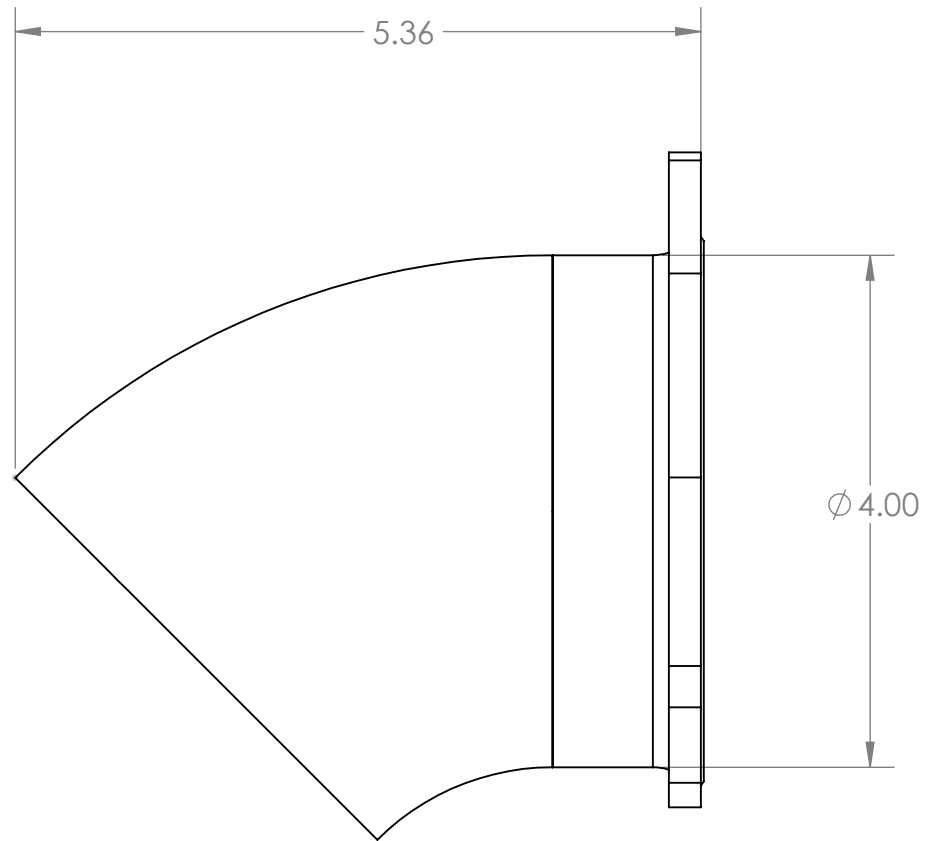
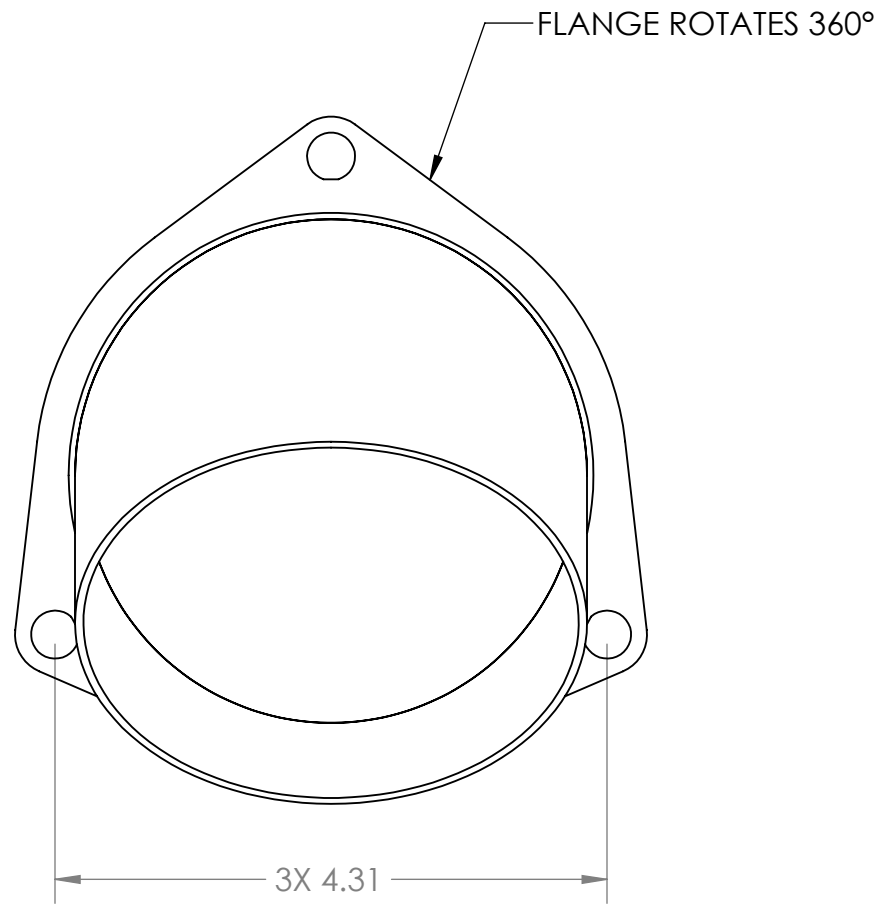

**QTP**  
QUICK TIME PERFORMANCE

UNLESS OTHERWISE SPECIFIED:			
INTERPRET WELDING SYMBOLS PER AWS A2.4:2007 INTERPRET SURFACE TEXTURE SYMBOLS PER ASME Y14.36-1996		INTERPRET DIMENSIONS & TOLERANCES PER ASME Y14.5M-1994	
3RD ANGLE 	UNITS: INCHES	ONE PLACE ± .030 TWO PLACES ± .020 THREE PLACES ± .010 ANGULAR ± 1	FILLETS R.002/R.020 BREAK EDGES .002/.020 RADIUS OR CHAMFER GENERAL FINISH 128 Rq MAX REMOVE ALL BURRS
MATERIAL		THIS DRAWING AND THE CONTENTS HERIN ARE CONFIDENTIAL AND THE SOLE PROPERTY OF QUICK TIME PERFORMACNE REPRODUCTION OF THIS DRAWING OR CONSTRUCTION OF ANY PARTS WITHIN THIS DRAWING ARE FORBIDDEN WITHOUT PRIOR WRITTEN CONSENT	
FINISH		DRAWN BY MP	DATE 11/19/2024
COMMENTS		CHECKED BY	DATE
WEIGHT:		TITLE: <b>4" UNIVERSAL TURN DOWN</b>	
SHEET 1 OF 1	SCALE: 2:3	SIZE <b>B</b>	DWG. NO. <b>11400_PDS</b>
		REV	