

DO NOT SCALE DRAWING  
FOR REFERENCE ONLY

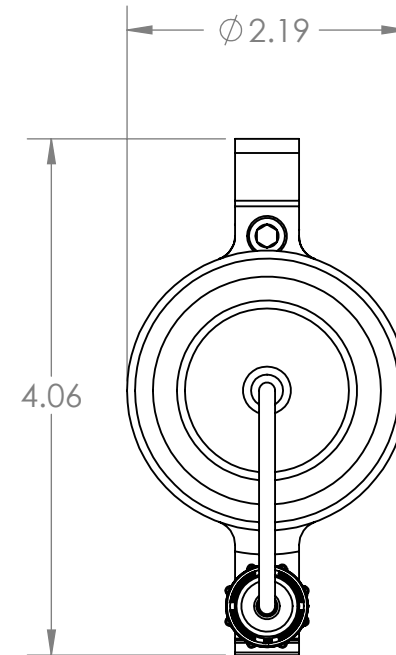
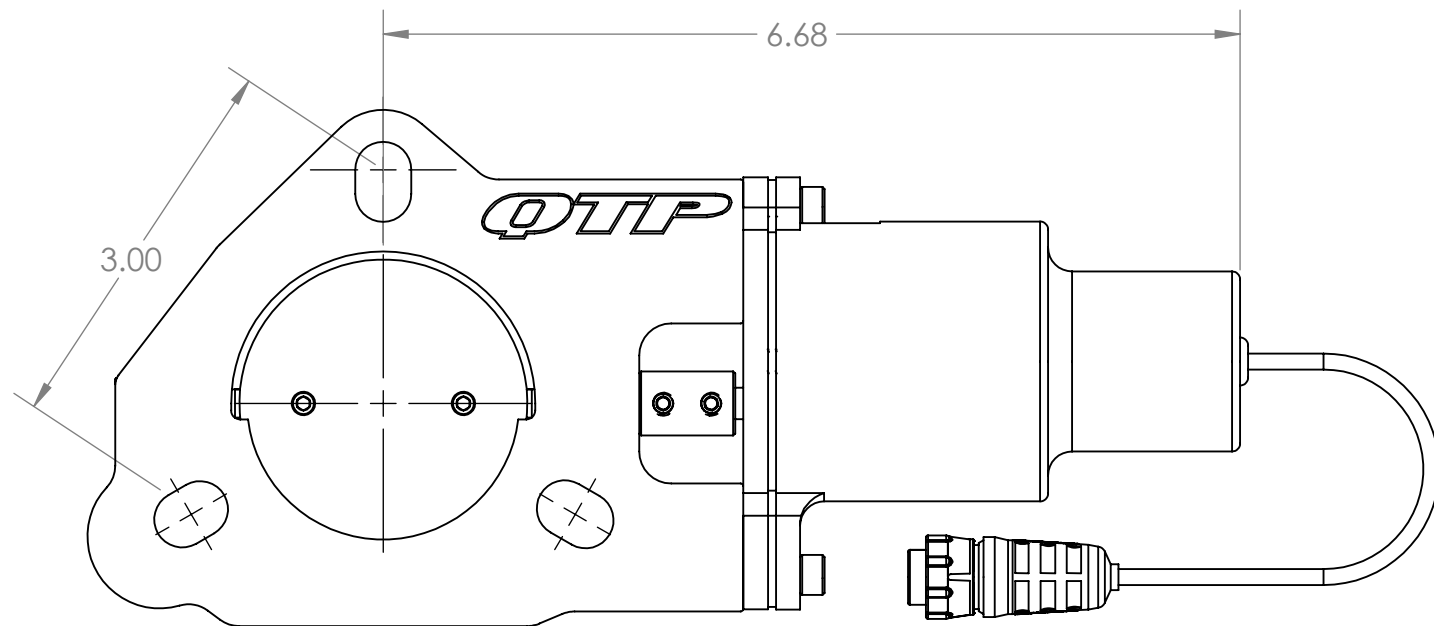
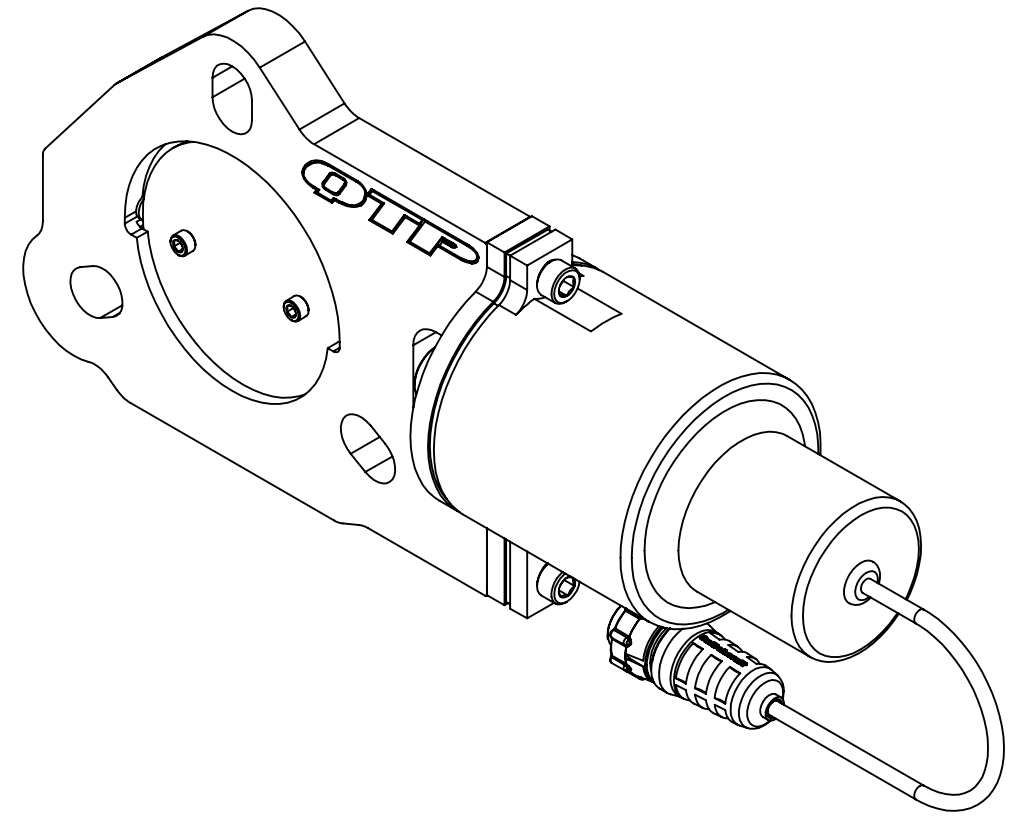
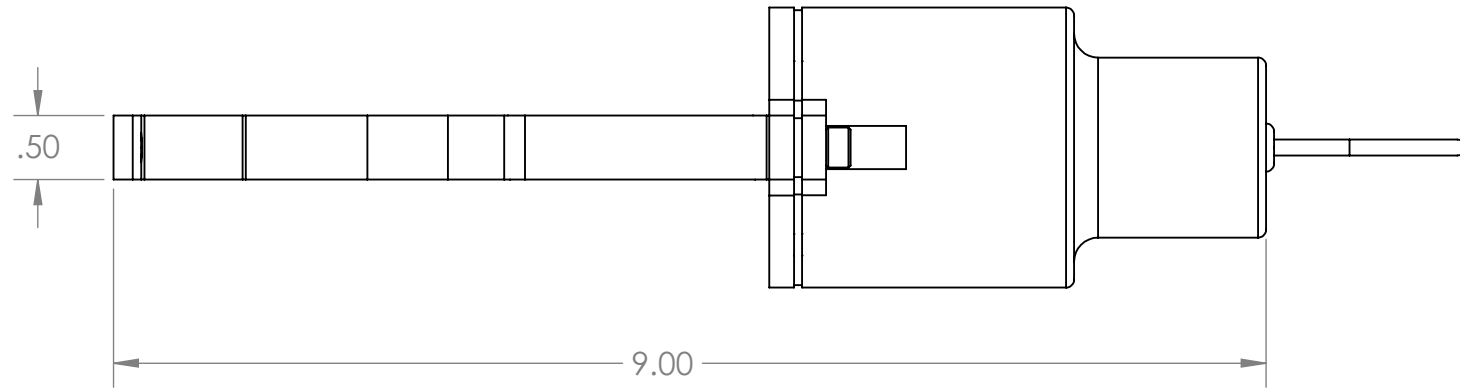

**QTP**  
QUICK TIME PERFORMANCE

UNLESS OTHERWISE SPECIFIED:			
INTERPRET WELDING SYMBOLS PER AWS A2.4:2007		INTERPRET DIMENSIONS & TOLERANCES PER ASME Y14.5M-1994	
INTERPRET SURFACE TEXTURE SYMBOLS PER ASME Y14.36-1996		FILLETS R.002/R.020	
3RD ANGLE	UNITS: INCHES	ONE PLACE $\pm .030$	BREAK EDGES .002/.020 RADIUS OR CHAMFER
		TWO PLACES $\pm .020$	GENERAL FINISH 128 Rq MAX
		THREE PLACES $\pm .010$	REMOVE ALL BURRS
MATERIAL		THIS DRAWING AND THE CONTENTS HERIN ARE CONFIDENTIAL AND THE SOLE PROPERTY OF QUICK TIME PERFORMACNE REPRODUCTION OF THIS DRAWING OR CONSTRUCTION OF ANY PARTS WITHIN THIS DRAWING ARE FORBIDDEN WITHOUT PRIOR WRITTEN CONSENT	
FINISH		DRAWN BY MP	DATE 4/20/2020
COMMENTS		CHECKED BY	DATE
WEIGHT:		TITLE: <b>2.25" ELECTRIC CUTOUT</b>	
SHEET 1 OF 1		SIZE <b>B</b>	DWG. NO. <b>QTEC225_PDS</b>
SCALE: 1:1.5		REV	