

DO NOT SCALE DRAWING
FOR REFERENCE ONLY

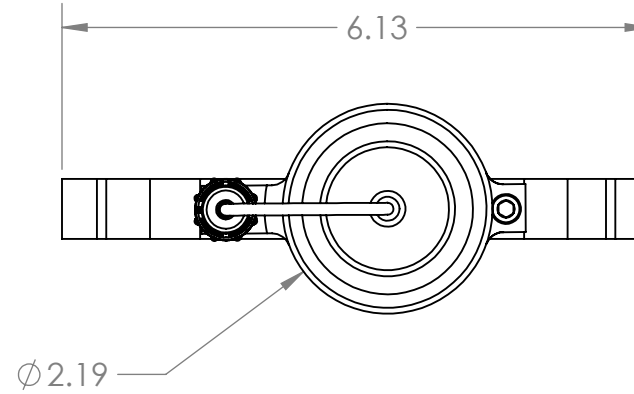
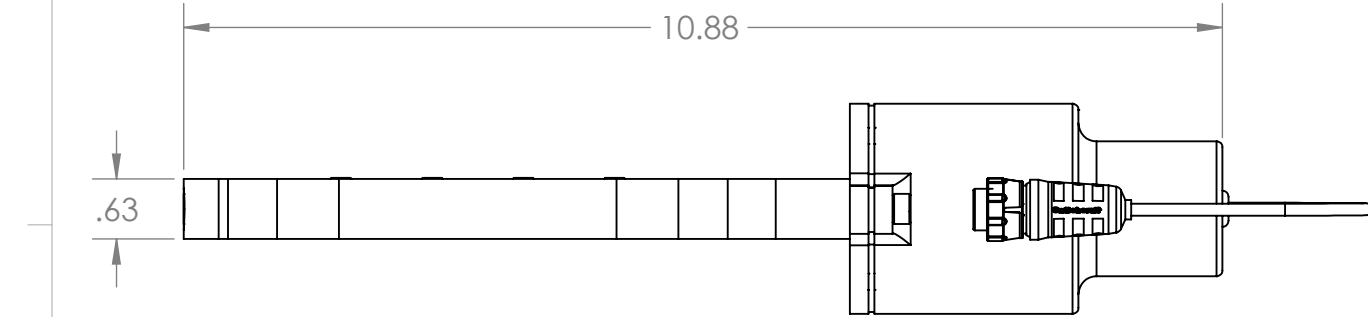
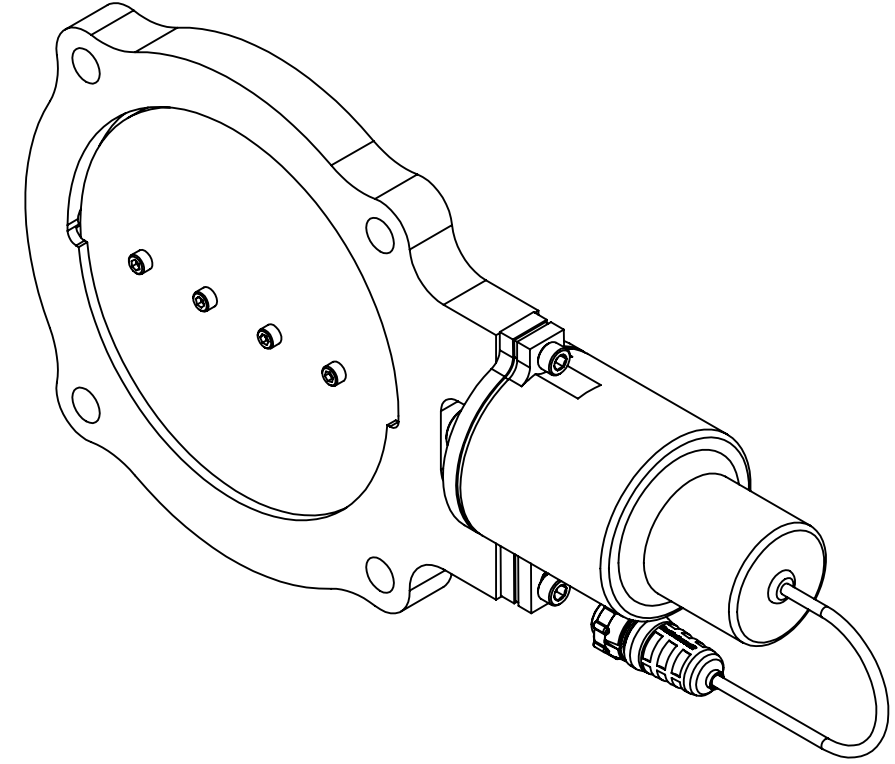
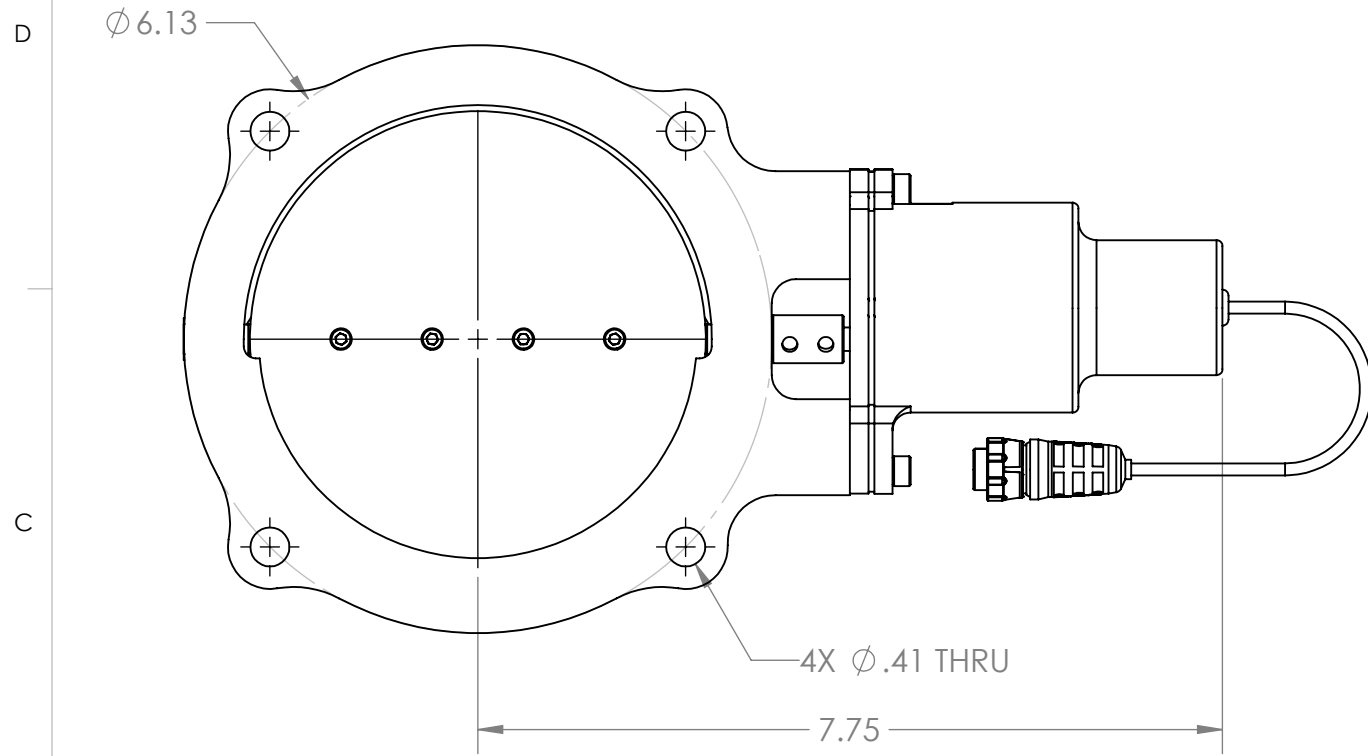

QTP
QUICK TIME PERFORMANCE

UNLESS OTHERWISE SPECIFIED:

<p>INTERPRET WELDING SYMBOLS PER AWS A2.4:2007 INTERPRET SURFACE TEXTURE SYMBOLS PER ASME Y14.36-1996</p> <p>3RD ANGLE </p>	<p>UNITS: INCHES</p> <p>ONE PLACE ± .030 TWO PLACES ± .020 THREE PLACES ± .010 ANGULAR ± 1</p>	<p>INTERPRET DIMENSIONS & TOLERANCES PER ASME Y14.5M-1994</p> <p>FILLETS R.002/R.020 BREAK EDGES .002/.020 RADIUS OR CHAMFER GENERAL FINISH 128 Rq MAX REMOVE ALL BURRS</p>
<p>THIS DRAWING AND THE CONTENTS HERIN ARE CONFIDENTIAL AND THE SOLE PROPERTY OF QUICK TIME PERMACNE REPRODUCTION OF THIS DRAWING OR CONSTRUCTION OF ANY PARTS WITHIN THIS DRAWING ARE FORBIDDEN WITHOUT PRIOR WRITTEN CONSENT</p>		
MATERIAL	DRAWN BY MP	DATE 12/19/2019
FINISH	CHECKED BY	DATE
COMMENTS	TITLE: 5.0" ELECTRIC CUTOUT	
WEIGHT:	SIZE	DWG. NO.
SHEET 1 OF 1	SCALE: 1:2	B QTEC5X_PDS
		REV