

# Installation Instructions

## QTEC Motor Replacement Guide

**Caution! Never work on a hot exhaust system. Burns or other serious injuries can result. Always allow the exhaust system to cool before removal. Always consult vehicle manual for proper lifting and support guidelines. Always wear approved safety glasses when working. Serious injury or death can result if safety precautions are not followed.**

### Tools Needed:

- 5/32 Allen Wrench
- 7/64 Allen Wrench
- 2.5mm Allen Wrench
- Penetrating Oil
- Loc-Tite (red)

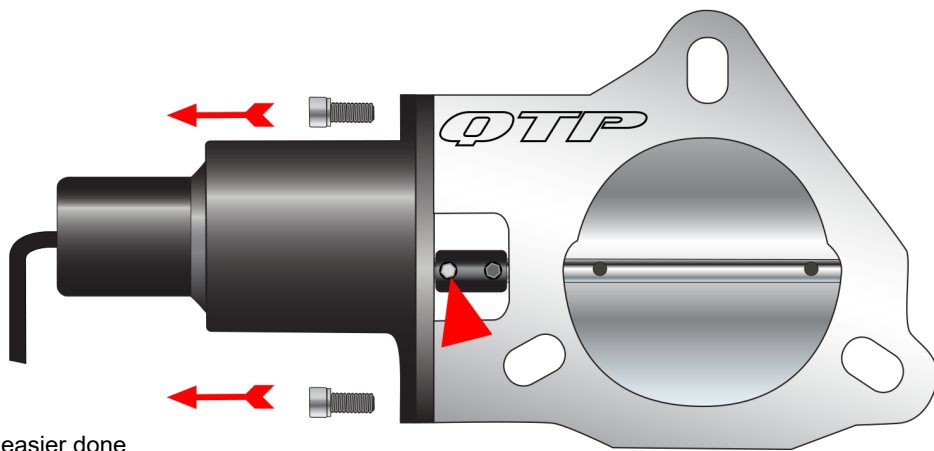

Remove the valve from the vehicle. The install is much easier done in the open or on a work bench. Unplug the twist-lock power connector and remove the 3 bolts holding the valve to your exhaust flange.

Next, remove the 2 Cap Screws holding the motor screw from MOTOR side. It may be necessary to use heat or a good penetrating oil to remove.

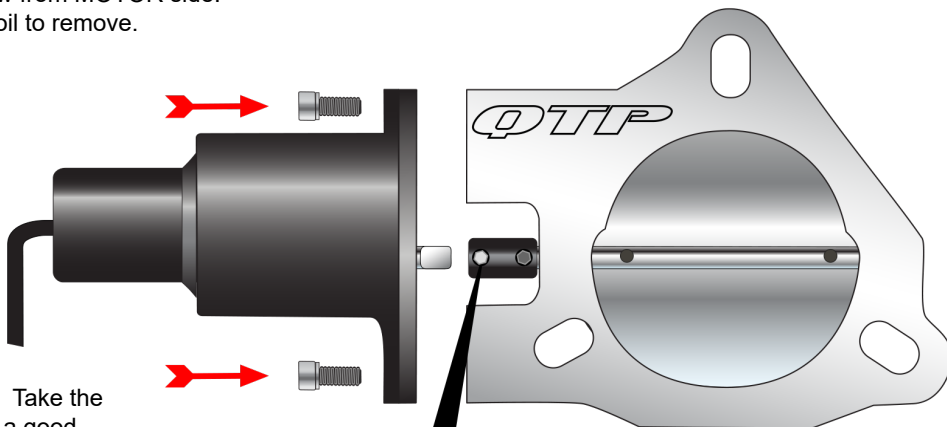

With the motor assembly removed from the valve body. Take the opportunity to clean the butterfly cutout body well using a good solvent and parts brush/toothbrush. Clean the ridge inside the housing well removing the carbon build-up, if any. CAUTION: The butterfly screws are tack welded. Attempting to loosen these screws will break them.

Wipe the body free of debris. Install the new coupler and then install the motor to the cutout body. We recommend applying a small amount of red Loc-Tite to the threads of the bolts during re-assembly to help protect against vibration.

Now making sure the FLAT side of the motor shaft is facing the set screw hole in the coupler. It may be necessary to apply power to the motor and rotate the motor shaft to achieve this position. See inset illustration for proper positioning for the shafts/coupler. Once achieved, slide the motor plate onto the valve body and again, using a small amount of red Loc-Tite to the threads, tighten your screws down.

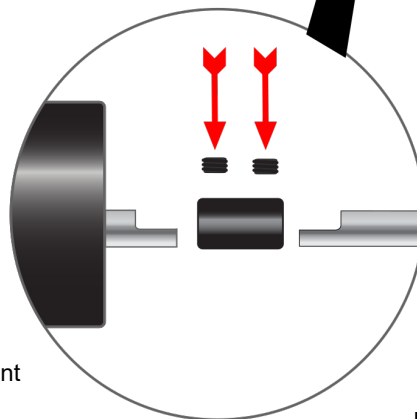

Finally, with your thumb pressing against the bottom of the butterfly (to ensure its in the closed position) tighten the set screw inside to coupler and secure that with Los-Tite as well.

**Technical Support**  
**Call: (864) 913-1999**  
**Monday through Friday**  
**9am - 4pm EST**  
**Email:**

[sales@quicktimeperformance.com](mailto:sales@quicktimeperformance.com)