

Installation Instructions

PART# 700114

2014-2015 Camaro SS

Eliminator System



Made in the USA

Caution! Never work on a hot exhaust system. Burns or other serious injuries can result. Always allow the exhaust system to cool before removal. Always consult vehicle manual for proper lifting and support guidelines. Always wear approved safety glasses when working. Serious injury or death can result if safety precautions are not followed.

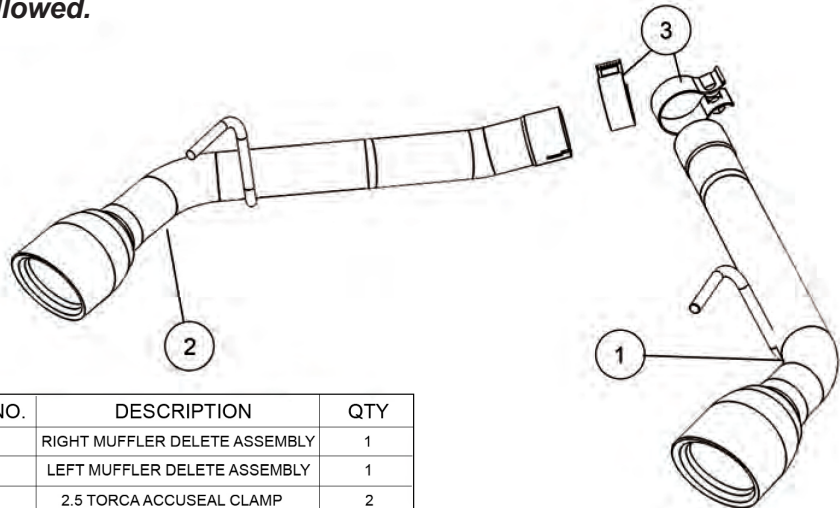

Tools Required:
 15mm Socket Ratchet
 Sawzall
 Tape Measure
 Spray lubricant

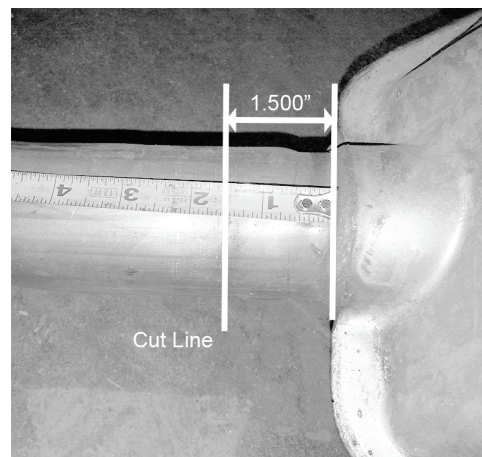

Figure 1.

Removal of Factory Equipment:

- Step 1:** Raise and support Vehicle. Using a tape measure mark the tube 1.5" from the weld seam of the rear mufflers, mark both sides. Take your time to ensure this measurement is properly marked. (Figure 1)
- Step 2:** Spray the rear factory hangers with spray lubricant. Using a sawzall or other cutting tool cut the tubes at the marks from step 1. Square the cut to the tube centerline.
- Step 3:** Carefully remove each muffler by removing the hangers from the rubber isolators. Once removed deburr the cut end of the remaining factory exhaust with a file. It is critical to remove all burrs as they may keep the new pipes from slipping over the factory exhaust.

Installation of New Exhaust

- Step 4:** Slide a 2.5" Torca accuseal clamp onto the end of each delete pipe.
- Step 5:** Slide the expanded end of the delete pipe over the factory exhaust. Spray some lubricant onto the hanger rod and slip it into the factory rubber isolators. Repeat for other side
- Step 6:** Slide the accuseal clamps into position, center the exhaust tip in the rear valence opening and snug exhaust clamps. Check final position and torque exhaust clamps to 35 ft-lbs. **Note:** it may be necessary to readjust the exhaust and retighten the clamps after the initial 20 mile drive cycle.

Note: After initial startup a small trace of smoke may be visible from the exhaust, do not be concerned. This is from residual oils left in the tube from the manufacturing process and will dissipate quickly.

Quick Time Performance recommends professional installation on all of our products.

Notice of Disclaimer and Liability

The Federal Government, each of the fifty states, local municipalities, towns and counties regulate emissions production, noise levels and safety standards. Quick Time Performance Inc make no warranties of merchantability, of fitness for a particular purpose, or that its products are approved for general use, or that its products comply with laws, regulations or ordinances in the states where they may be sold to the ultimate purchaser, the consumer. Unless stated otherwise on our website, instruction sheet or price list, all risk to the conformity of any of the products offered by Quick Time Performance. Inc. or its affiliates in any such state and as to repair should the product prove defective or non-conforming, is on the retail purchaser, the buyer, the ultimate consumer of such product and it is not upon the seller, distributor or manufacturer. In this connection, the retail purchaser, the buyer, the ultimate consumer assumes the burden of the entire cost of any and all necessary service, alterations or repair. The foregoing statement LIMITS THE LIABILITY OF QUICK TIME PERFORMANCE.COM INC. AND ITS AFFILIATES. QUICK TIME PERFORMANCE, INC. AND ITS AFFILIATES ASKS THAT YOU REMEMBER THAT RACING VEHICLES NEVER BE DRIVEN ON A HIGHWAY OR STREETS ANY WHERE IN THE UNITED STATES. It is illegal to remove or render inoperative any emission control device on any vehicle. Our products are intended for racing vehicles, which have never been intended to be driven on any highway or any street in the United States. In California Vehicle code sections 27156 and 38391 prohibit the advertising, offering for sale, or installation of any device, which modifies a vehicles emission control system unless exempted. Quick Time Performance.Com Inc. and its affiliates have not received an exemption from these code sections and are not legal for sale or use in California on vehicles originally equipped with a catalytic converter. Our products are for racing vehicles, which are never intended for highway or street use. Our products are subject to price change without notice. We reserve the right to reject and cancel any order.

Warranty

Quick Time Performance Inc. provides a limited warranty against defects in materials and workmanship for a period of 90 days from date of sale to the original purchaser. Upon inspection and verification of warranty, Quick Time Performance will, at its option, repair or replace products, which prove to be defective.

Exclusions & Limitations

- Any product , which has been subjected to abuse, accident , alteration, neglected maintenance or improper installation, renders the product warranty null and void.
- Conditions resulting from acts of nature, weather, criminal activity or accidents are subject to adjustment under the product warranty.
- Shipping and handling charges are the responsibility of the end user and are not covered by warranty.
- Any and all labor charges that may be incurred for the removal and or replacement of any covered component or the purpose of affecting this warranty are the sole responsibility of the consumer.
- Leakage

Return Policy

Quick Time Performance Inc. will not accept shipments without prior authorization. In the event it is necessary to return an unused product within 30 days, a return of goods authorization must be obtained from Quick Time Performance Inc. A letter of explanation should be included in the package as well as an invoice or receipt.

Questions

Quick Time Performance Technical Team is available Monday through Friday (9am-4pm eastern time) at (864) 913-1999 or via email at: sales@quicktimeperformance.com