

8 7 6 5 4 3 2 1

DO NOT SCALE DRAWING  
FOR REFERENCE ONLY

D

C

B

A

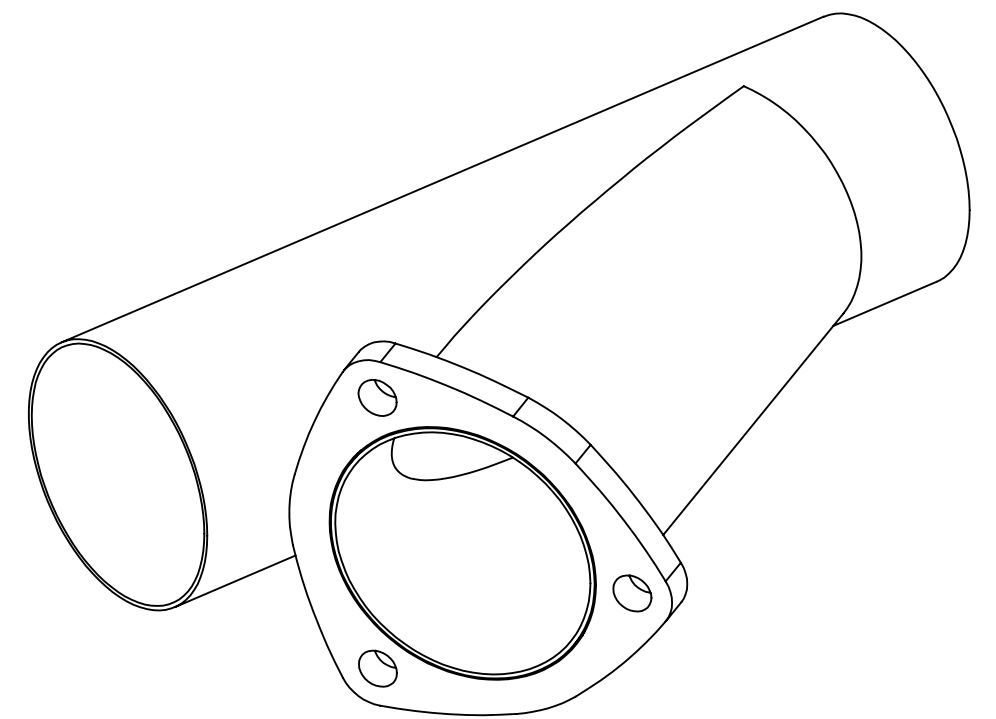
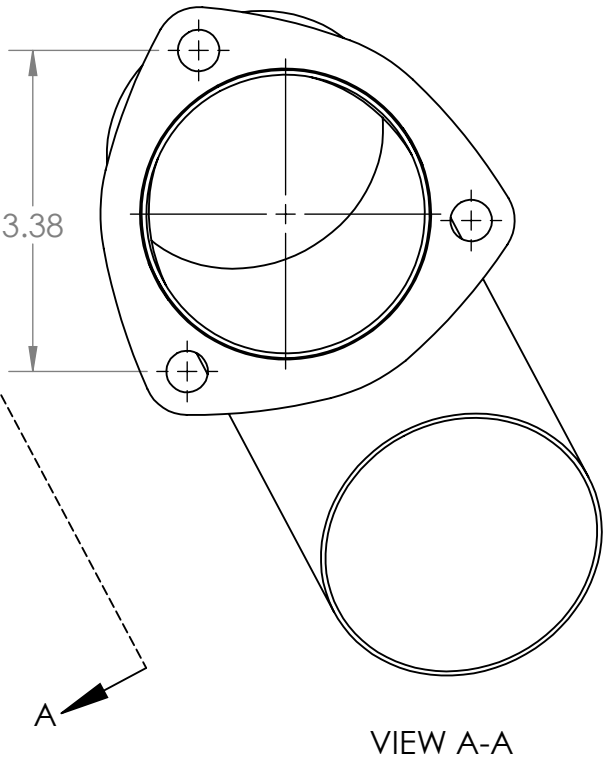
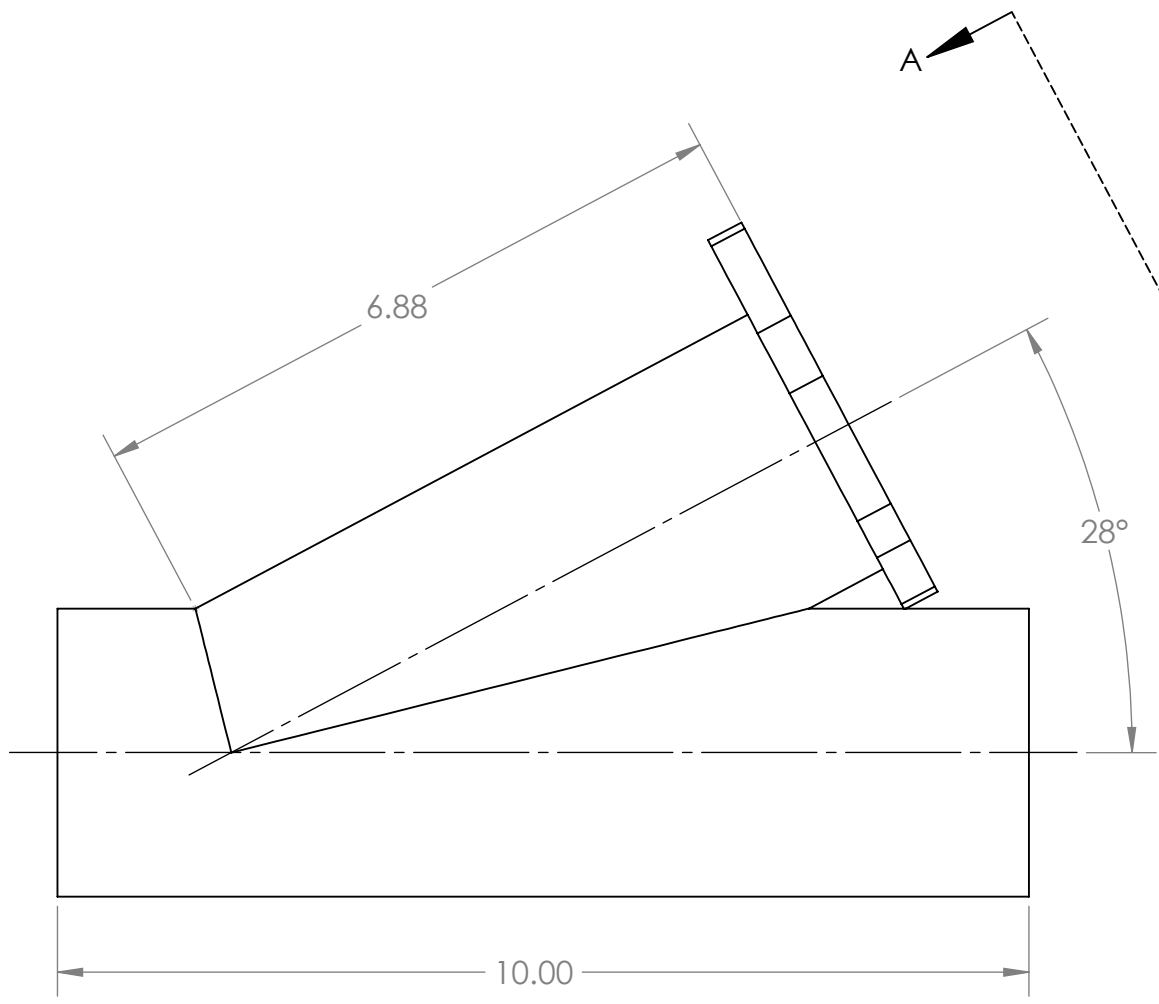

D

C

B

A

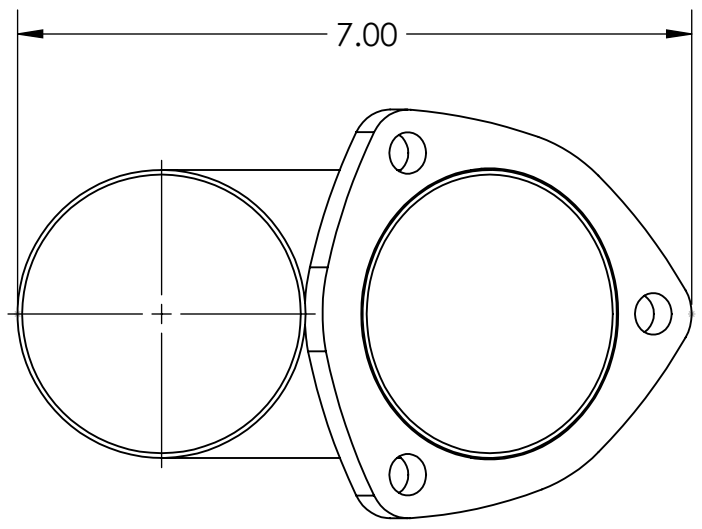
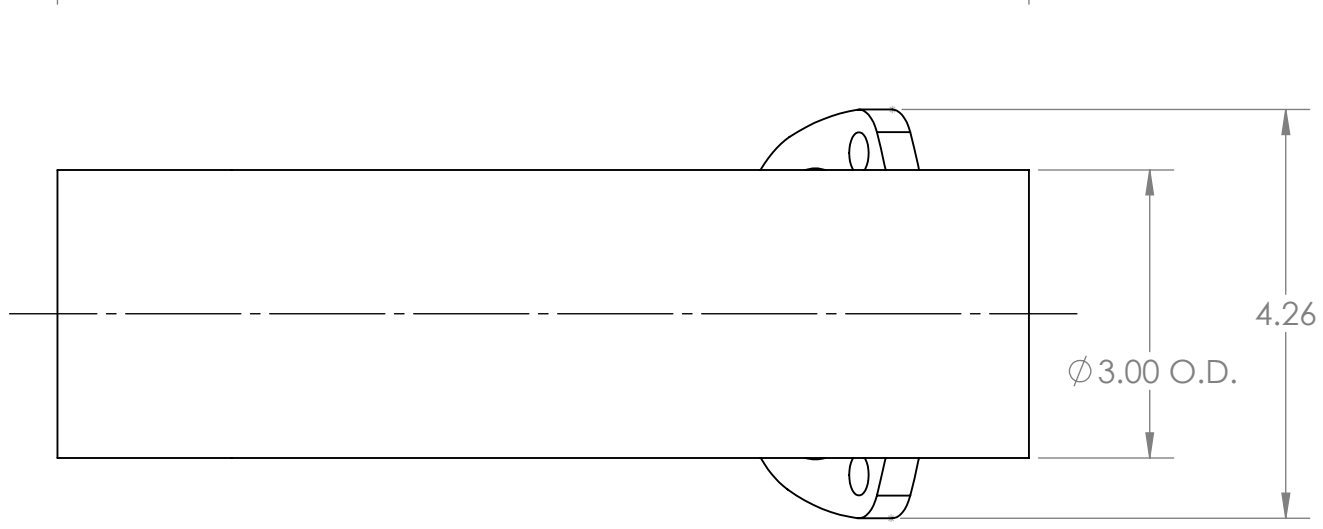

UNLESS OTHERWISE SPECIFIED:			
INTERPRET WELDING SYMBOLS PER AWS A2.4:2007		INTERPRET DIMENSIONS & TOLERANCES PER ASME Y14.5M-1994	
INTERPRET SURFACE TEXTURE SYMBOLS PER ASME Y14.36-1996		FILLETS R.002/R.020	
3RD ANGLE		BREAK EDGES .002/.020 RADIUS OR CHAMFER	
UNITS: INCHES		GENERAL FINISH 128 Rq MAX	
ONE PLACE ± .030		REMOVE ALL BURRS	
TWO PLACES ± .020			
THREE PLACES ± .010			
ANGULAR ± 1			
THIS DRAWING AND THE CONTENTS HERIN ARE CONFIDENTIAL AND THE SOLE PROPERTY OF QUICK TIME PERMACNE REPRODUCTION OF THIS DRAWING OR CONSTRUCTION OF ANY PARTS WITHIN THIS DRAWING ARE FORBIDDEN WITHOUT PRIOR WRITTEN CONSENT			
MATERIAL	DRAWN BY	DATE	CHECKED BY
	MP	4/20/2020	
FINISH	TITLE:		
	3.0" STAINLESS CUTOUT		
COMMENTS	SIZE	DWG. NO.	REV
	B	10300_PDS	
WEIGHT:			
SHEET 1 OF 1	SCALE: 1:2		

8 7 6 5 4 3 2 1