

Installation Instructions

PART# 725018

2018-2024 Jeep Wrangler JL Crawler Eliminator Muffler



Made in the USA

Caution! Never work on a hot exhaust system. Burns or other serious injuries can result. Always allow the exhaust system to cool before removal. Always consult vehicle manual for proper lifting and support guidelines. Always wear approved safety glasses when working. Serious injury or death can result if safety precautions are not followed.

ITEM NO.	DESCRIPTION	QTY.
1	TAILPIPE ASSEMBLY	1
2	INLET TUBE	1
3	2.5 TORCA ACCUSEAL CLAMP	1

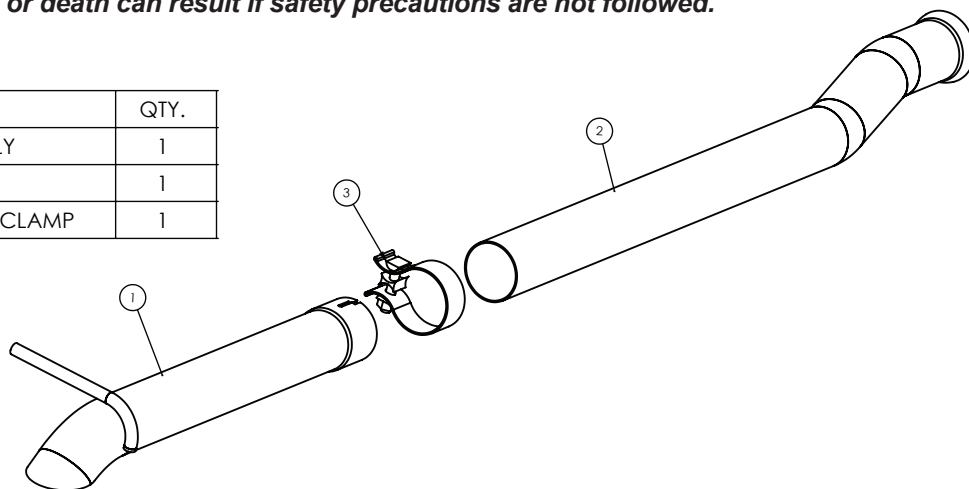

Removal of Factory Exhaust

- Step 1:** Raise and support Vehicle. Locate and loosen the band clamp securing the factory axle back exhaust. Remove the 2 rear factory hangers (1 each side) from the rubber isolators and remove the factory axle back.
- Step 2:** Locate and loosen the swivel seal clamp at the front of the factory intermediate pipe. With the clamp loose, remove the rear hanger from the rubber isolator and remove the intermediate pipe from the vehicle.
- Step 3:** There is a lock tang that holds the swivel seal clamp to the factory intermediate pipe. Using a screwdriver or small pry tool, release this tang and remove the factory swivel seal clamp. Save this clamp for installation of your new exhaust. (Image A).

Installation of New Exhaust

NOTE: If being installed on a **2 door** model wrangler, the inlet tube must be cut down. Measure and cut off 21 5/8" (549 mm) from the NON-flared end of the inlet tube. Make sure the cut is straight and deburr the cut end with a file. **Only trim the inlet tube for the 2 door model**

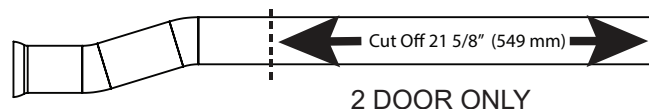

- Step 4:** Slide the swivel seal clamp from step 3 onto the new inlet pipe. Slide the flared end of the new inlet pipe onto the ball end of the factory cat pipe. Tighten the clamp just enough to hold the inlet tube in place but still allow rotation. (Image B)
- Step 5:** Slide the accuseal clamp onto the inlet tube. Use a spray lubricant to lube the end of the hanger and slide it into the factory rubber isolator in front of the rear axle. Then slide the tailpipe assembly onto the inlet pipe. (Image C)
- Step 7:** With everything in place, align the exhaust system so the tailpipe/inlet tube assembly is parallel to the framerail. Ensure there is proper clearance between the exhaust systems and all nearby components. Tighten all clamps at this time.



Image A



Image B



Image C

Note: After initial startup a small trace of smoke may be visible from the exhaust, do not be concerned. This is from residual oils left in the tube from the manufacturing process and will dissipate quickly. Check & re-torque ALL clamps after your first 50 miles after your new install.

Quick Time Performance recommends professional installation on all of our products.

Notice of Disclaimer and Liability

The Federal Government, each of the fifty states, local municipalities, towns and counties regulate emissions production, noise levels and safety standards. Quick Time Performance Inc make no warranties of merchantability, of fitness for a particular purpose, or that its products are approved for general use, or that its products comply with laws, regulations or ordinances in the states where they may be sold to the ultimate purchaser, the consumer. Unless stated otherwise on our website, instruction sheet or price list, all risk to the conformity of any of the products offered by Quick Time Performance. Inc. or its affiliates in any such state and as to repair should the product prove defective or non-conforming, is on the retail purchaser, the buyer, the ultimate consumer of such product and it is not upon the seller, distributor or manufacturer. In this connection, the retail purchaser, the buyer, the ultimate consumer assumes the burden of the entire cost of any and all necessary service, alterations or repair. The foregoing statement LIMITS THE LIABILITY OF QUICK TIME PERFORMANCE.COM INC. AND ITS AFFILIATES. QUICK TIME PERFORMANCE, INC. AND ITS AFFILIATES ASKS THAT YOU REMEMBER THAT RACING VEHICLES NEVER BE DRIVEN ON A HIGHWAY OR STREETS ANY WHERE IN THE UNITED STATES. It is illegal to remove or render inoperative any emission control device on any vehicle. Our products are intended for racing vehicles, which have never been intended to be driven on any highway or any street in the United States. In California Vehicle code sections 27156 and 38391 prohibit the advertising, offering for sale, or installation of any device, which modifies a vehicles emission control system unless exempted. Quick Time Performance.Com Inc. and its affiliates have not received an exemption from these code sections and are not legal for sale or use in California on vehicles originally equipped with a catalytic converter. Our products are for racing vehicles, which are never intended for highway or street use. Our products are subject to price change without notice. We reserve the right to reject and cancel any order.

Warranty

Quick Time Performance Inc. provides a limited warranty against defects in materials and workmanship for a period of 90 days from date of sale to the original purchaser. Upon inspection and verification of warranty, Quick Time Performance will, at its option, repair or replace products, which prove to be defective.

Exclusions & Limitations

- Any product, which has been subjected to abuse, accident, alteration, neglected maintenance or improper installation, renders the product warranty null and void.
- Conditions resulting from acts of nature, weather, criminal activity or accidents are subject to adjustment under the product warranty.
- Shipping and handling charges are the responsibility of the end user and are not covered by warranty.
- Any and all labor charges that may be incurred for the removal and or replacement of any covered component or the purpose of affecting this warranty are the sole responsibility of the consumer.
- Leakage

Return Policy

Quick Time Performance Inc. will not accept shipments without prior authorization. In the event it is necessary to return an unused product within 30 days, a return of goods authorization must be obtained from Quick Time Performance Inc. A letter of explanation should be included in the package as well as an invoice or receipt.

Questions

Quick Time Performance Technical Team is available Monday through Friday (9am-4pm eastern time) at (864) 913-1999 or via email at: sales@quicktimeperformance.com