

Installation Instructions

PART# 500116

2016 - 2024 Camaro SS 6.2L Agressor Pipes



Made in the USA

Caution! Never work on a hot exhaust system. Burns or other serious injuries can result. Always allow the exhaust system to cool before removal. Always consult vehicle manual for proper lifting and support guidelines. Always wear approved safety glasses when working. Serious injury or death can result if safety precautions are not followed.

ITEM NO.	DESCRIPTION	QTY.
1	LEFT AGGRESSOR TUBE	1
2	Right Aggressor Tube	1
3	3.00 GASKET	2
4	3.00 IN ELECTRIC CUTOUT	2
5	3/8 SAE FLAT WASHER	6
6	3/8-16 x 1.75" HEX BOLT	6
7	3/8-16 SERRATED FLANGE NUT	6

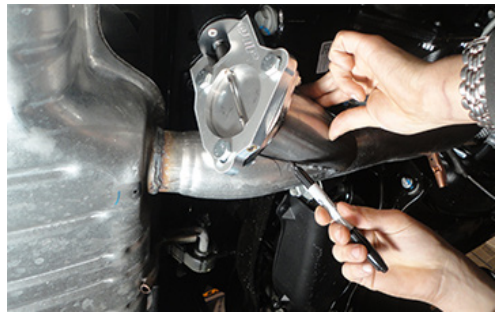
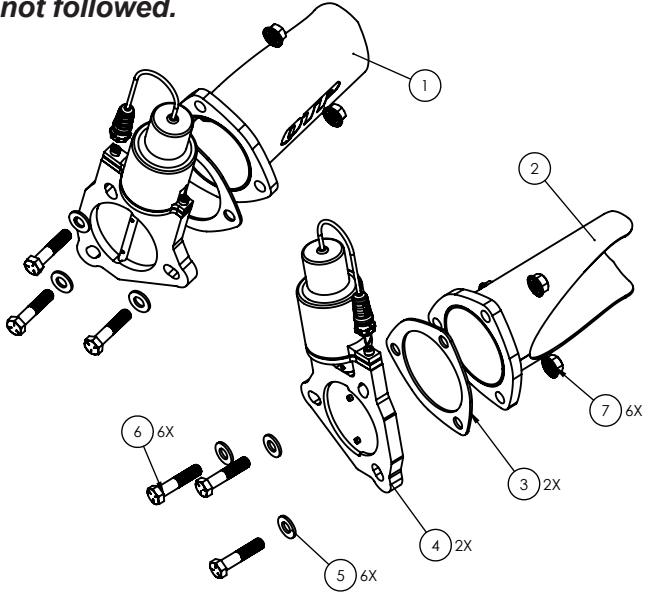

Image A

Installing the Cutout Pipes

- *NOTE***: The pipes are different for each side. When mounted correctly, the QTP logo on the TUBE will face up.
- Mount the Electric Valve to the connection tube flange and check to be sure you have the valve aligned to the connection tube correctly. See Image F for proper orientation. Ensure that there is proper clearance between the motor and chassis (Specifically the rear sway bar).
- With the valve bolted to the cutout pipe, position the notched end of the pipe on the factory exhaust. Using a marker mark the outside of the pipe where it contacts the factory exhaust (Image A).
- Offset this line inboard approximately 1/4" (Image B). Using a hole saw or plasma cutter cut the hole using the inner line as a guide (Image C).
- Deburr the cut using a die grinder, dremel tool or file (Image D). With the valve still bolted to the cutout tube, align the cutout tube over the hole now cut in the factory exhaust. Ensure proper clearance between the valve and chassis is maintained and tack the tube into position.
- Remove the valve and weld the Cutout pipes onto the exhaust (Image E).

Installing the Toggle Switch

- Make sure that the vehicle battery has been disconnected.
- The switch should be located in a place that is easy to access such as a center console, kick panel, etc.
- Connect the RED wire to a 12 volt source.
- Connect the BLACK wire to a good ground.
- Drill a 1/2" hole where you wish to mount the switch.
- Remove the first lock ring from the shaft of the switch.
- Install switch in the hole you just drilled.
- Slide the lock ring over the switch and tighten ring so that there is no play in switch.

Routing the Wire Harness

- Make sure that you have the wire oriented so that the connectors mate. They are different, so make sure you pull the proper end into the vehicle.
- Route the wire up through the underside of the car. *Be careful to ensure that that the exhaust pipes or drive shaft do not interfere with the cable.
- Route the cables into the car. You can often open up a factory drain plug in the floor pan and snake the wire through.
- For manual transmission cars, you can also come up through the transmission shifter area. Remove the boot/seal of the transmission shifter.
- Plug the cable into the toggle switch, on the connector near the motor, align and press them together and then turn the coupling ring until it locks.



Image B



Image C



Image D

Installing the QTEC

- Position the QTEC over the collector of the cutout pipe. Place the QTEC on the bolts on the cutout with the gasket. Coat all bolts liberally with a thread locker. Start the nuts on all four bolts before tightening. Be sure that the butterfly does not come into contact with the mounting flange.



Image E



Image F

Finishing the Install

- Reconnect the positive lead on the battery.
- Lower the vehicle back to the ground.
- Before starting vehicle, turn key to run position and push up and down to open and close the valve. Ensure that the valve is not binding or sticking (i.e. is centered in the exhaust and is not hitting any objects). It only takes 4.75 seconds for it to go from closed to open and vice versa.
- Start the car and enjoy!

Maintenance

- Check & re-torque ALL clamps after 50 miles miles of your new install.
- We recommend lubricating the butterfly plate, Body and shaft using a quality lubricant such as "Liquid Wrench"(tm) from Gunk. This will help prevent Carbon build up naturally generated by the exhaust system and keep the butterfly sealing properly. This should be done on a monthly basis.
- For harsher climates, you should remove the cutouts and store them. Using the supplied block off plates will insure operation while cutouts are removed.
- Check screws every now and then to make sure they are tight. If not reapply a red thread locker and reinstall.

Note: After initial startup a small trace of smoke may be visible from the exhaust, do not be concernend. This is from residual oils left in the tube from the manufacturing process and will disipate quickly.

Quick Time Performance recommends professional installation on all of our products.

Notice of Disclaimer and Liability

The Federal Government, each of the fifty states, local municipalities, towns and counties regulate emissions production, noise levels and safety standards. Quick Time Performance Inc make no warranties of merchantability, of fitness for a particular purpose, or that its products are approved for general use, or that its products comply with laws, regulations or ordinances in the states where they may be sold to the ultimate purchaser, the consumer. Unless stated otherwise on our website, instruction sheet or price list, all risk to the conformity of any of the products offered by Quick Time Performance. Inc. or its affiliates in any such state and as to repair should the product prove defective or non-conforming, is on the retail purchaser, the buyer, the ultimate consumer of such product and it is not upon the seller, distributor or manufacturer. In this connection, the retail purchaser, the buyer, the ultimate consumer assumes the burden of the entire cost of any and all necessary service, alterations or repair. The foregoing statement LIMITS THE LIABILITY OF QUICK TIME PERFORMANCE.COM INC. AND ITS AFFILIATES. QUICK TIME PERFORMANCE, INC. AND ITS AFFILIATES ASKS THAT YOU REMEMBER THAT RACING VEHICLES NEVER BE DRIVEN ON A HIGHWAY OR STREETS ANY WHERE IN THE UNITED STATES. It is illegal to remove or render inoperative any emission control device on any vehicle. Our products are intended for racing vehicles, which have never been intended to be driven on any highway or any street in the United States. In California Vehicle code sections 27156 and 38391 prohibit the advertising, offering for sale, or installation of any device, which modifies a vehicles emission control system unless exempted. Quick Time Performance.Com Inc. and its affiliates have not received an exemption from these code sections and are not legal for sale or use in California on vehicles originally equipped with a catalytic converter. Our products are for racing vehicles, which are never intended for highway or street use. Our products are subject to price change without notice. We reserve the right to reject and cancel any order.

Warranty

Quick Time Performance Inc. provides a limited warranty against defects in materials and workmanship for a period of 90 days from date of sale to the original purchaser. Upon inspection and verification of warranty, Quick Time Performance will, at its option, repair or replace products, which prove to be defective.

Exclusions & Limitations

- Any product , which has been subjected to abuse, accident , alteration, neglected maintenance or improper installation, renders the product warranty null and void.
- Conditions resulting from acts of nature, weather, criminal activity or accidents are subject to adjustment under the product warranty.
- Shipping and handling charges are the responsibility of the end user and are not covered by warranty.
- Any and all labor charges that may be incurred for the removal and or replacement of any covered component or the purpose of affecting this warranty are the sole responsibility of the consumer.
- Leakage

Return Policy

Quick Time Performance Inc. will not accept shipments without prior authorization. In the event it is necessary to return an unused product within 30 days, a return of goods authorization must be obtained from Quick Time Performance Inc. A letter of explanation should be included in the package as well as an invoice or receipt.

Questions

Quick Time Performance Technical Team is available Monday through Friday (9am-4pm eastern time) at (864) 913-1999 or via email at: sales@quicktimeperformance.com